



**Curva a 90° Profipress XL
con SC-Contur**

- estremità a pressare femmina

Fornitura

O-ring EPDM, ghiera dentate, anelli separatori

Modello 2416XL

articolo 476 847

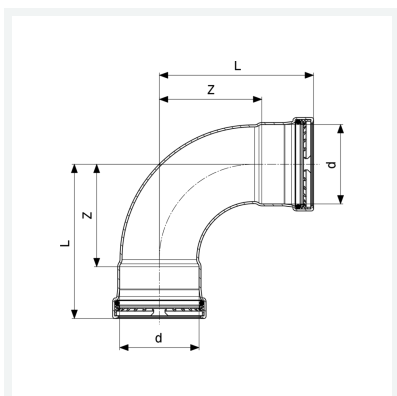

Caratteristiche

Diametro esterno del tubo	d	76,1
Dimensione	Z	99 mm
Lunghezza	L	149 mm
Peso	1265 g	
Volume	4144 cm ³	
Materiale	rame	